

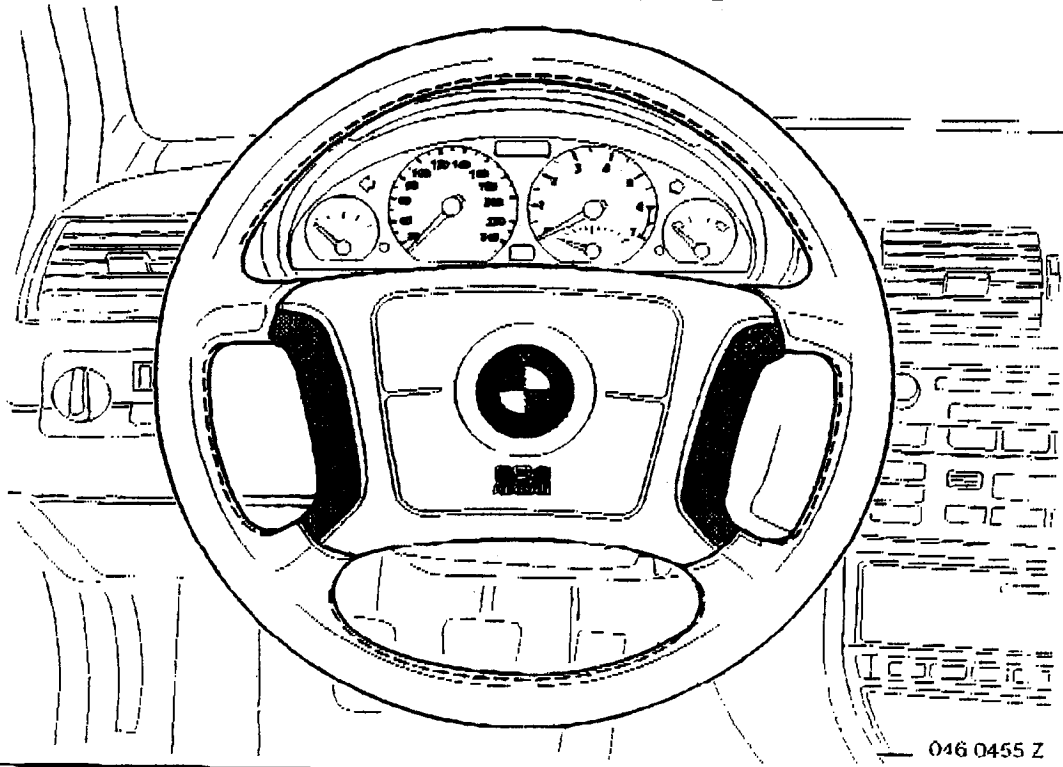

Parts and Accessories Installation Instructions



046 0455 Z

Multi-functional steering wheel (MFL) retrofit kit Cruise control (GRA)

Retrofit kit for BMW 3 Series identical to standard equipment until 6/00

Coupe (E46/2) with N42 or M54 engine
touring (E46/3) with M47, M54 or M57 engine
Saloon (E46/4) with M47 or M57 engine and M54 engine from 09/98

Retrofit/Installation kit No.

65 71 0 016 106
65 71 0 016 108

Contents

Section	Page
1. Important notes	13
2. Necessary preparatory work on the vehicle	14
3. Overview of retrofit wiring harness MFL/GRA	15
4. Install and connect retrofit wiring harness MFL/GRA	16
5. Change steering wheel	18
6. Install MFL steering wheel	20
7. Finalising operations	21
8. Circuit diagram, cruise control system E46	22

1. Important Notes

The retrofit kit is intended only for use in the BMW trading organisation.
The installation instructions are only valid for vehicles with SMART airbag sports steering wheel. These are E46 coupé, touring, saloon as from 06/99 and convertible from start of series.

Installation time

Installation time is approx. 1 hour.

The installation time can vary according to the condition and fittings of the vehicle.

Target group

Target group for these installation instructions are technical personnel who have received training on BMW vehicles and who have specialist knowledge of the body electrical system.

Tasks

Carry out all maintenance, repair and installation work on BMW vehicles on own authority.

All operations should be carried out with the aid of the current BMW

- repair instructions

- circuit diagrams

in a logical sequence using the prescribed tools (special tools) whilst observing the applicable safety regulations.

Assembly note

All work is represented on a left-hand drive vehicle. For a right-hand drive vehicle, all work must be carried out in mirror image.

Required tools and auxiliary materials

1/4 inch ratchet box

1/4 inch Torx spanner socket T 30

1/2 inch ratchet box

Torque spanner

Set of flat-tip screwdrivers

Set of Phillips screwdrivers

Special tool, folding stick (00 9 321)

Hand lamp

Side-cutting pliers

Crimping tool (61 9 041)

Matrix for crimping tool (61 9 042)

Wire stripper (61 9 043)

2. Necessary preparatory work on the vehicle

	TIS AW No.
 Observe safety regulations on dealing with components of the airbag system. ◀	32 34
Carry out short test	
Disconnect battery	12 00
Dismantle airbag unit	32 34 020
Dismantle steering wheel	32 33 000
Dismantle bottom part of steering column shroud	32 31 020
Undo top part of steering column shroud	31 003
Dismantle glove box on driver's side	51 16 350
Dismantle foot-pedal trim panel	51 45 185
Dismantle decorative strip at light switch	51 16 221
Dismantle switch unit for light	61 31 033
Dismantle cover of E-box	

3. Overview of retrofit wiring harness MFL/GRA

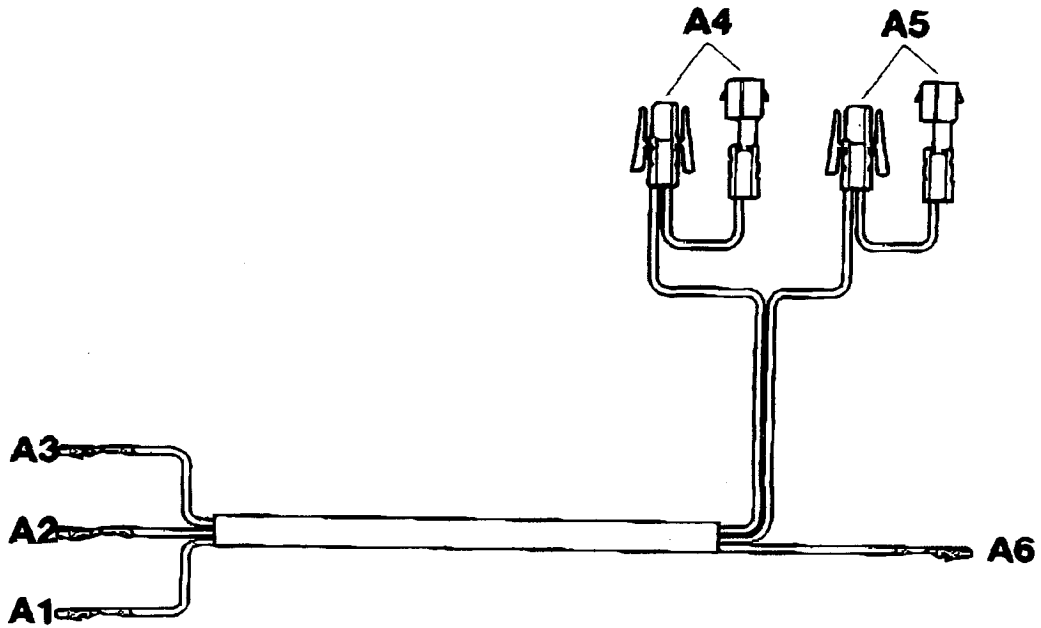

F 46 0309 2W

Branch cable	Designation	Signal	Cable colour/ cross-section	Connection point in vehicle	Pin designation Pin space
A1	Blade terminal contact	DME/ DDE	BL/SW 0.35 mm ²	At the steering column switch fixture plug-in connector, 10-pole, green	X10170 PIN 8
A2	Blade terminal contact	K-Bus	WS/RT/GE 0.35 mm ²	At the steering column switch fixture plug-in connector, 10-pole, green	X10170 PIN 9
A3	Blade terminal contact	Kl. R	VI/GE 0.5 mm ²	At the steering column switch fixture plug-in connector, 10-pole, green	X10170 PIN 10
A4	Twin-lead terminal	Kl. R	VI/GE 0.5 mm ²	At the light switch central contr. unit A3 plug-in connector, 54-pole, black	X12 PIN 27
A5	Twin-lead terminal	K-Bus	WS/RT/GE 0.35 mm ²	At the light switch central contr. unit A3 plug-in connector, 54-pole, black	X12 PIN 21
A6	Blade terminal contact	DME/ DDE	BL/SW 0.35 mm ²	At the DME/DDE contr. unit A60004 plug-in connector, 40-pole, black	X60004 PIN 27

4. Install and connect retrofit wiring harness MFL/GRA

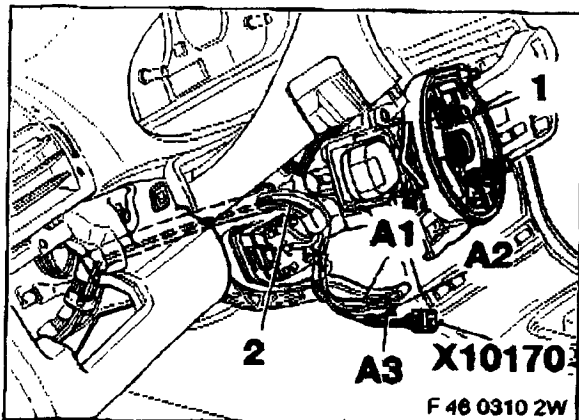

Unpin green 10-pole plug-in connector X10170 from the switch fixture (1). Install retrofit wiring harness (2) along the cable guide at the steering column to plug-in connector X10170. Pin branch cab. **A1 - A3** into plug-in con. X10170 as follows:

Branch cable	Cable colour	Pin-space	Plug-in connector	Signal
A1	BL/SW	8	X10170	K-Bus
A2	WS/RT/GF	9	X10170	KI. R
A3	VI/GE	10	X10170	DME/DDE

Fit plug-in connector X10170 (1) in the terminal and connect to the switch fixture (2)

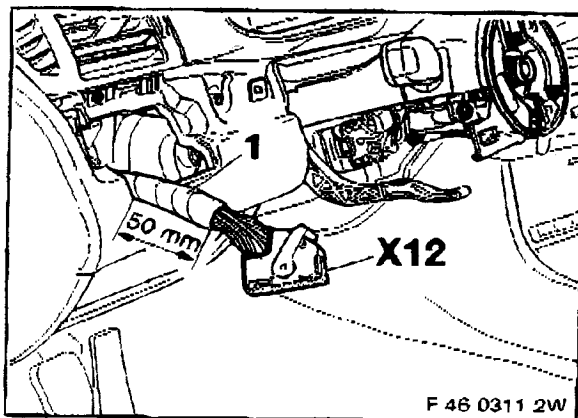

Remove wiring harness insulation (1) to a length of approx. 50 mm.

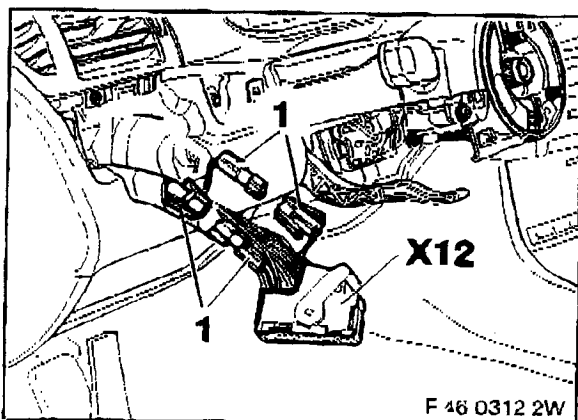

Cut through leads VI/GE (pin 27) and WS/RT/GE (pin 21), which are going away from plug-in connector X12, at approx. 40 mm behind plug-in connector X12. Provide lead ends in each case with a 1-pole socket/pin contact and insulating housing (1). Install branch cables **A4 - A5** of the retrofit wiring harness to plug-in connector X12.

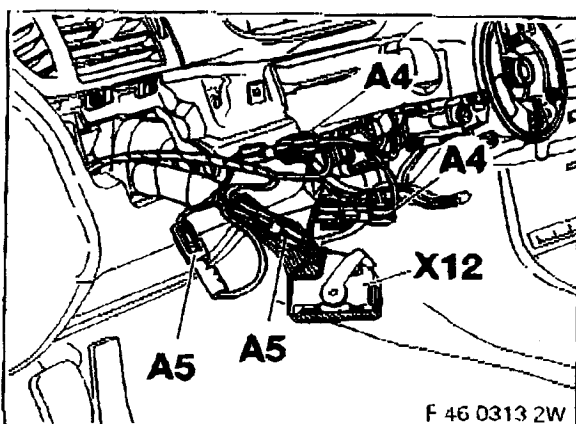

Connect branch cable **A4**, cable colour VI/GE, with the lead VI/GE which comes from plug-in connector X12, PIN 27. Connect branch cable **A5**, cable colour WS/RT/GE in the same way as described above with the WS/RT/GE lead coming from plug-in connector X12, PIN 21.

4. Install and connect retrofit wiring harness MFL/GRA

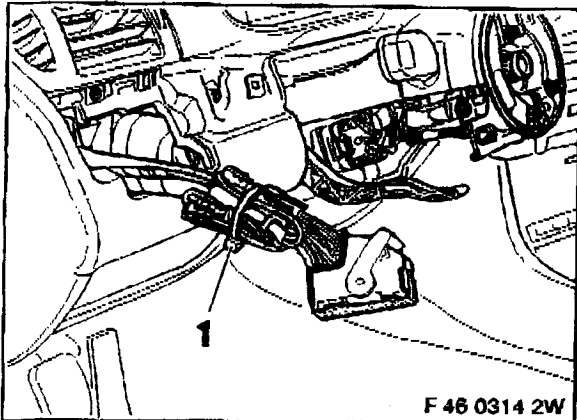

Fasten plug-in connectors as shown to the wiring harness with supplied cable strap (1).

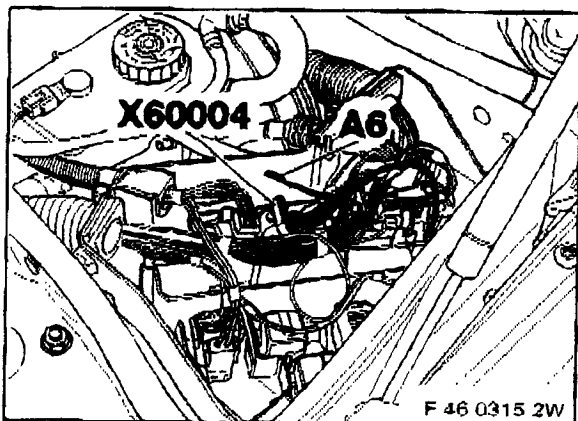

In right-hand drive vehicles, the tied-back lead of branch cable **A6** must be opened up. Then install branch cable **A6** through the corrugated tube behind the heater/air conditioner to the left side of the vehicle and from there into the E-box. ◀

Install branch cable **A6** through the cable lead-through into the E-box. Pull off connector **X60004** at the DME/DDE control unit.

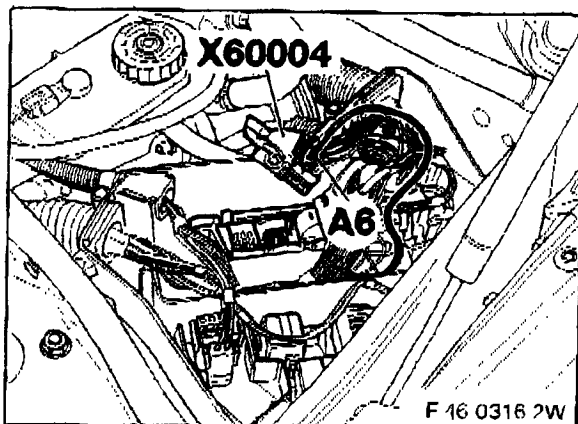

Release connector **X60004** and plug in branch cable **A6**, cable colour **BL/SW** at PIN 27. Assemble connector **X60004** and plug on to DME/DDE control unit again.

5. Change steering wheel

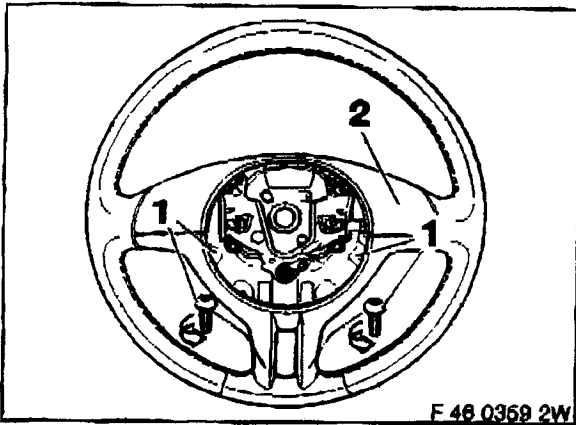

Screw out TORX screws (1) and remove covering cap (2).

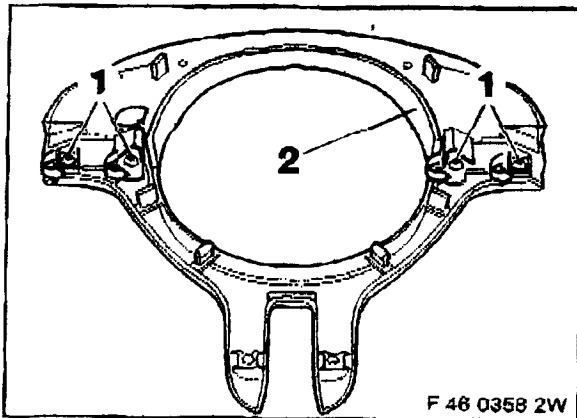

Screw out TORX screws (1) and remove upper part (2).

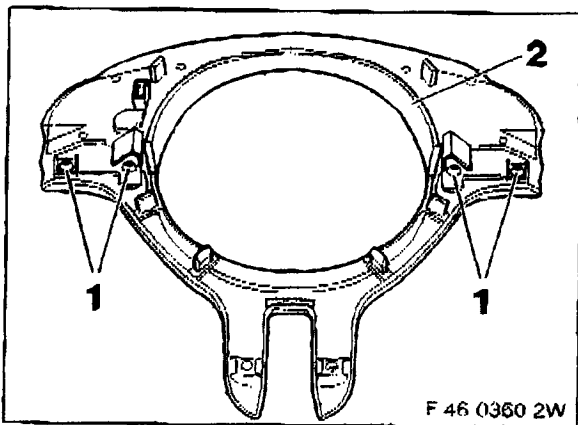

Put on switch unit (2) and fasten with the TORX screws (1).

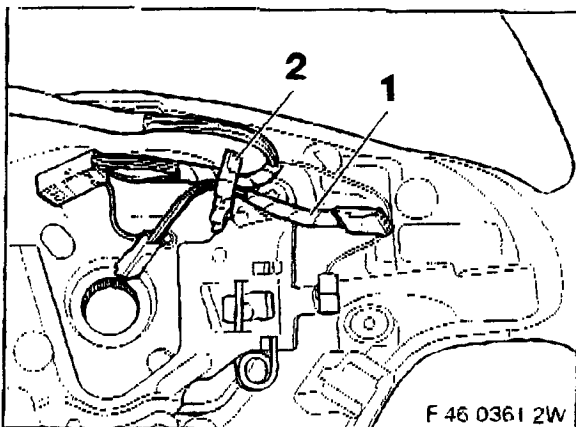

Attach connecting cable (1) supplied with the installation kit in the cable strap (2).

5. Change steering wheel

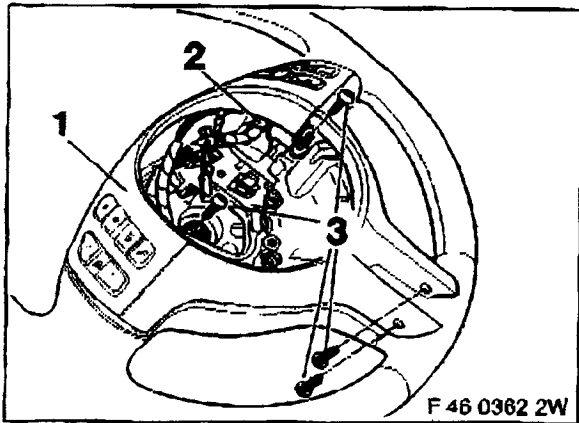

Put on covering cap (1) with switch unit. Plug in connecting cable (2). Fasten covering cap (1) with the TORX screws (3).

6. Install MFL steering wheel.

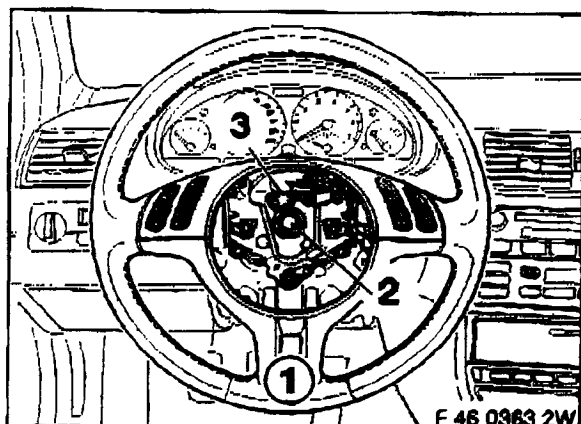

Fit sports steering wheel (1) and screw on screw (2) with a tightening torque of 63 Nm. Plug connector (3) on to the switch fixture.

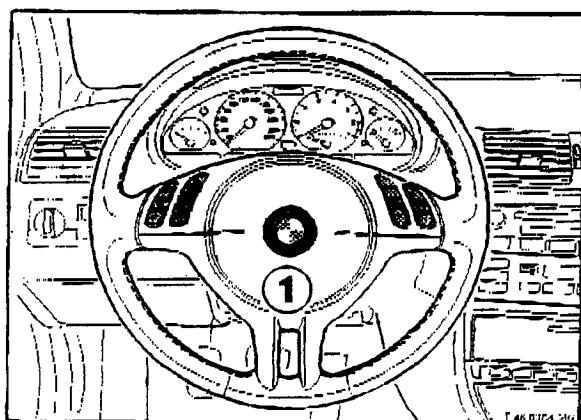

Fit existing airbag unit (1).

7. Finalising operations

1. Reassemble vehicle in the reverse order of disassembly.
2. Carry out short test.
3. Coding of the vehicle must not be carried out.
4. Carry out function test (more detailed functions relating to operation of the retrofit MFL/GRA are described in the vehicle or radio instruction manual).

8. Circuit diagram, cruise control system E46

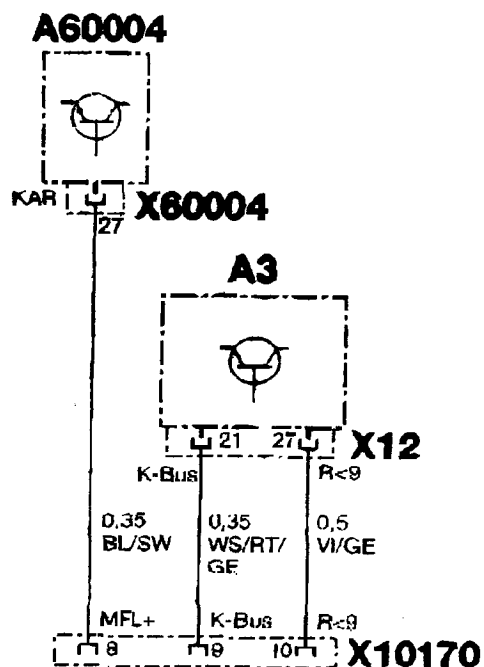

F 16 0321 R

Key

- A3 Control unit light switch central control unit
A60004 Control unit DME/DDE
X12 Connector, 54-pole, black, at light switch central control unit
X10170 Connector, 10-pole, green, at the switch fixture
X60004 Connector, 40-pole, black, at the DME/DDE control unit

Cable colours

- BL/SW blue/black
VI/GE violet/yellow
WS/RT/GE white/red/yellow